

THE 10 SYSTEM

PRECAST SWIMMING POOL



For 100% sustainable construction



System 10

The new revolutionary '**System 10**' pool tank construction system uses the latest in design innovation making the once impossible, possible. To construct level deck swimming pools in record time by using an interlocking pre-cast concrete panel system.

The '**System 10**' precast panels are easily assembled giving a guaranteed perfect finish to the final structure and come complete with an integrated pool surround drainage channel.

Once the pool tank is constructed using the '**System 10**' waterproof concrete precast panels, a 'Hydroelastic' membrane system is then applied and the pool tank is then ready for tiling using the 'Ergo System' range of porcelain pool tiles from "Rosa Gres".

The overall result of using the '**System 10**' level deck pool design in conjunction with the Ergo Tile System, is simplicity which offers a guarantee of a faster construction time, greater durability and strength and resistance within the pool tank construction process from start to finish.

'**System 10**' is unique and completely unmatched by any other system.



The New System: Perfect Design, Robust and Fast Construction (Complies to FINA and ASA standards and regulations)

'**System 10**' consists of specially designed, inter-locking, pre-cast concrete panels that are lifted into position by crane and assembled directly onto a load bearing, concrete floor slab.

The pre-cast panels have integrated design features which assist with the accurate positioning, levelling and assembly of the pool tank. Once set into position, the precast panels are securely connected together by high strength threaded rods to the rear of the panels.

The interlocking '**System 10**' Panels form the walls of the level deck pool tank as well as the pool perimeter complete with the overflow drainage channel.

The joints between the water proof pre-cast concrete panels are sealed using a high quality polyurethane sealant, which ensures that the '**System 10**' pool tank is completely watertight.

The pool tank floor is then cast in situ. The result of this is a perfectly level and watertight structure.

Once this assembly work has been completed, the pool tank is then ready for tiling using the "Rosa Gres Ergo System" porcelain pool tiles. This tile system is perfectly designed to fit the '**System 10**' panels exactly achieving a hygienic, resistant, quality and long lasting finish.

key S10 features

Walls

Made of waterproof pre-cast concrete panels, built in compliance to strict quality standards conforming to the required EN norms and BS standards (i.e. BS8007 : 1987 for the Design of concrete structures for retaining aqueous liquids).

The pre cast concrete panels are built to a resistance of HA 40N/mm².

Manufacturing is totally automated and subject to regular external quality controls.

The reinforcement used within the panels and to connect the panels to the pool base reinforcement, are made of high quality B500 Steel that is secured into position by separators. An efficient anchoring system is also set into position to avoid panel movement and thus preventing tile displacement & failure.

The moulds utilise high frequency vibrators to ensure density and efficient compaction of the concrete.

The concrete is allowed to set in a controlled environment to ensure it maintains constant properties throughout the year.

Base

The precast panels are set into position on a 100mm base of blinding concrete.

The load bearing floor slab is a minimum of 200mm depth using 25N/mm² concrete, reinforced with a # 15x15 Ø12mm single mesh and perimeteric reinforcement of 200x250mm.



ADJUSTABLE BASE PANEL



STEP PANEL



INSIDE CORNER PANEL

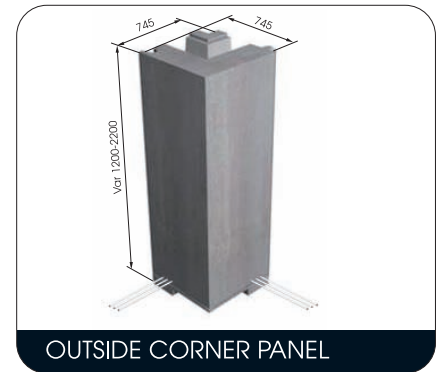

OUTSIDE CORNER PANEL

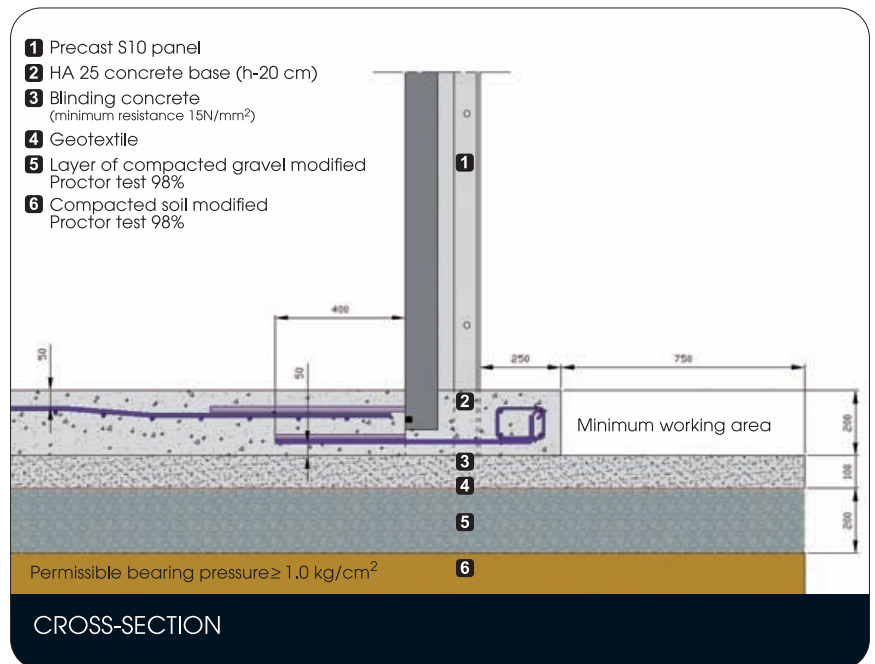

CROSS-SECTION

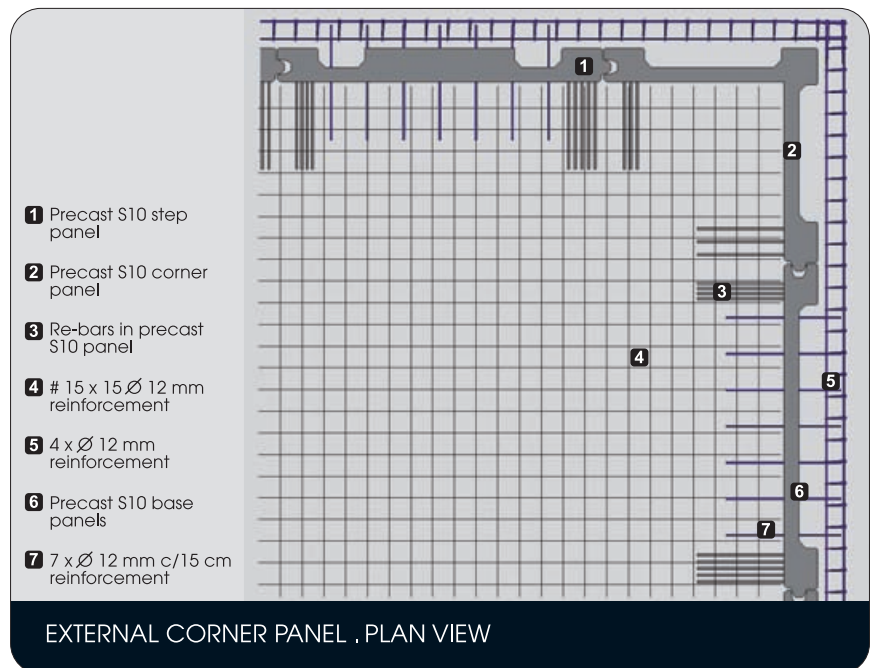

EXTERNAL CORNER PANEL , PLAN VIEW

key S10 features

Water tightness

Using strict quality controls during production and within the curing process, the materials used guarantee that the panels are watertight.

Various processes ensure that the vertical joints between the panels are watertight:

1. Additive '**S10 grout**' filling in between the panel joints to attain a solid joint.

2. Polyethylene joint backing as a base for the polyurethane joint.

3. Application of an '**S10 polyurethane elastic sealant**' joint for final waterproof sealing between panels.

All joints between the panels and the floor slab are made watertight by following several stages during the construction process:

1. Fitting of '**Fuga Stop**' hydro-expansive polyurethane cord in the purpose designed groove at the bottom of the panels before the concrete base is poured.

2. Fitting of polyurethane cord along the joints between panels and filling as a safety backup measure.

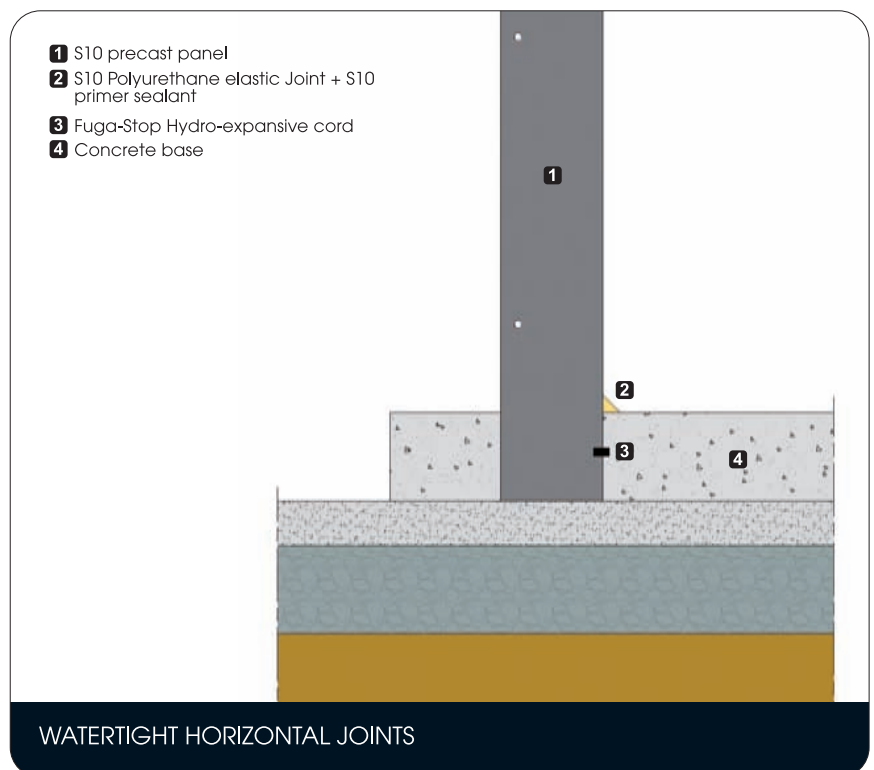
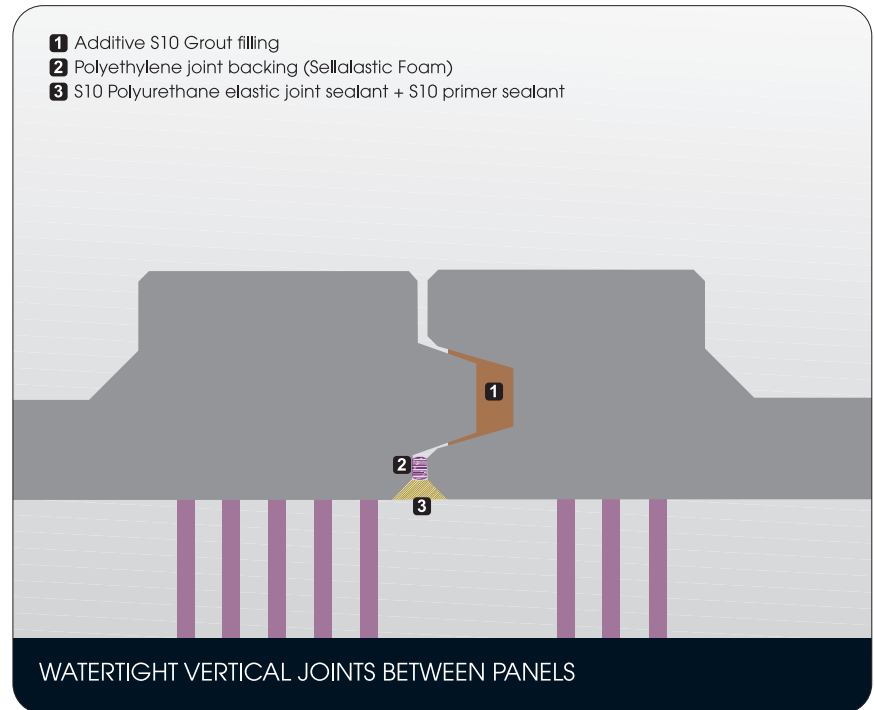

key S10 features

Solutions for connecting the S10 System to the pool perimeter floor slab

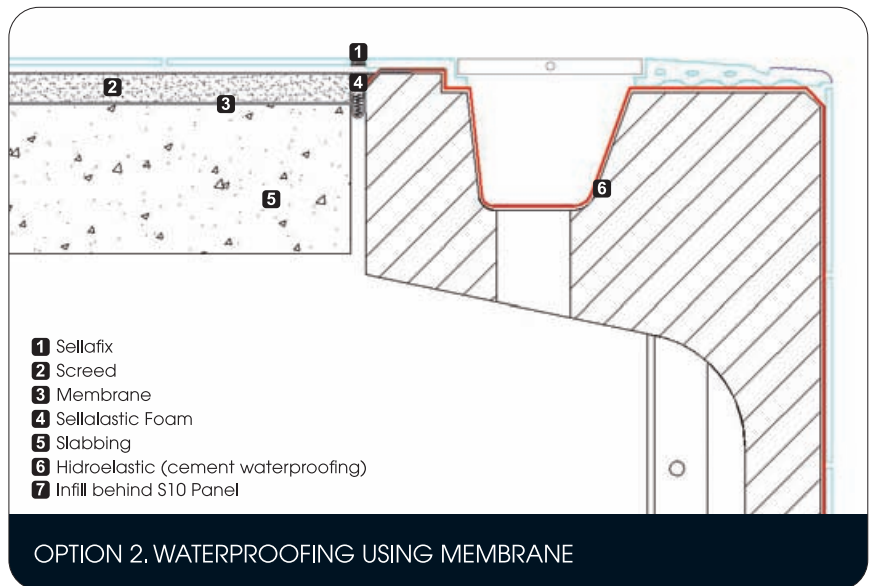
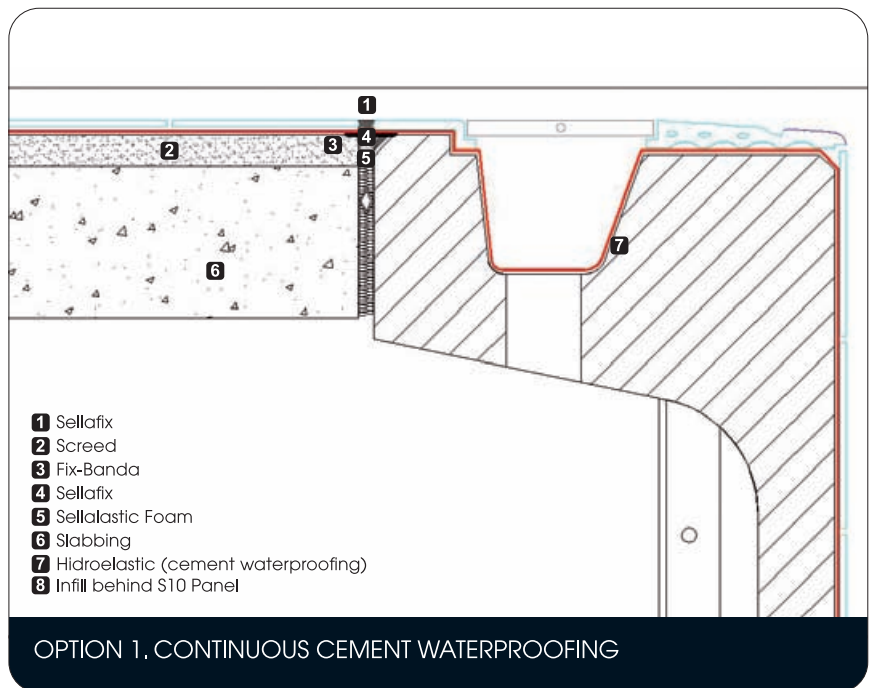

Specifications

System 10 has been designed for the construction of rectangular swimming pools.

Tanks of any length can be built.

Panels can be produced to accommodate pool depths of between 1.0 and 2.0 metres. For shallower depths, screeds are used to form the base.

Floor Gradients and ramps are constructed at a later stage.

It is recommended that wall fittings (return cables, lighting, etc.) be anticipated in the design so that panels can be supplied with these in position. However, it is possible to cut these onsite if required.

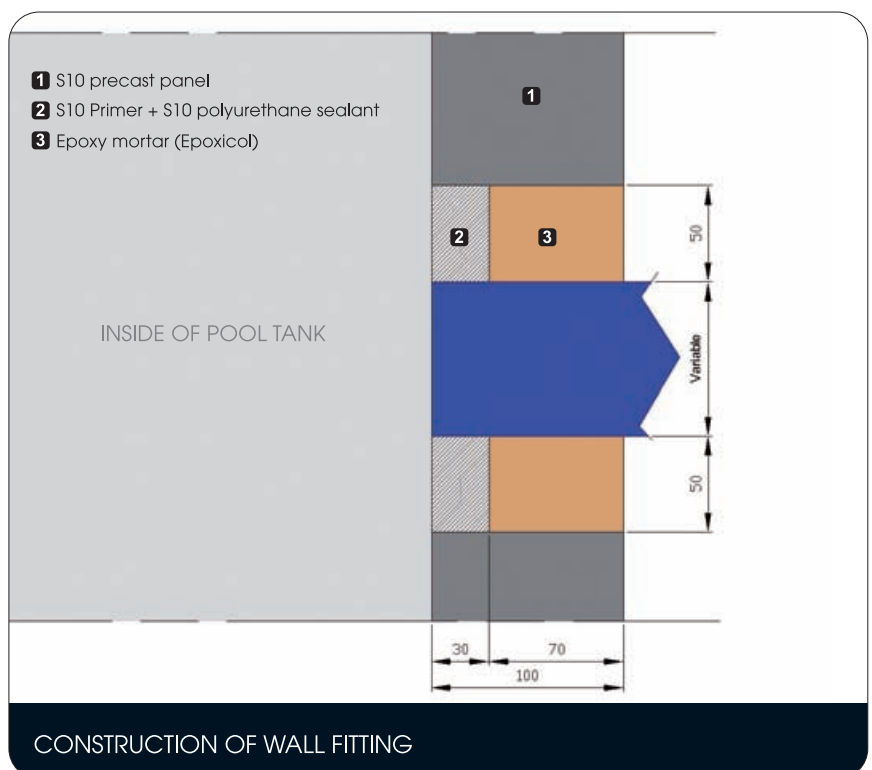

S10

Construction Time

Approximate completion time of a 12.5m x 25.0m pool using the **S10 System**

Operations undertaken by **POOL BUILDING CONTRACTOR**

Operations to be undertaken by **MAIN CONTRACTOR**

Assembly of panels, 3 days.

Completion of base (*), 3 days.

Sealing of vertical and perimeter joints (**), 2 days.

Primary Water tightness testing (as per recommendations).

Secondary Waterproofing, 2 days.

(*) The concrete of the base must be left to set for a minimum of 7 days before proceeding with sealing.

(**) The joints must be left to polymerise for a minimum of 10 days before water tightness testing is conducted.

Onsite layout of the tank according to the design specifications.

Assembly of panels.

Filling of joints with non-shrink mortar.

Fitting of hydro-expansive polyurethane cord.

Adjustment of panel connecting bolts.

Sealing of horizontal and vertical joints.

Completion of perimeter formwork, base slabbing and perimeter reinforcement, and pouring of concrete for the base of the pool floor.

Additional building work (edging, falls to floor, ramps, steps, etc.).

Backup sealing of tank (cement waterproofing).

Ceramic tiling.

Wall Fittings inc grouts and movement joints.

Geotechnical survey of the land and calculation of the panel load-bearing slab.

Preparation (to design calculations) excavation, compaction, levelling and construction of the panel and floor slab load-bearing base.

Additional costs for access to site if a trailer is unable to reach the pool tank.

Water tightness testing.

S10 step by step

Stages of construction for a 12.5 m x 25 m pool.

Load-bearing base for the panels



Prior to the assembly of **System 10**, a resistant load-bearing base is required that is perfectly level. A layer of blinding concrete can be used in the case of tanks on ground level. In the case of raised tanks, load-bearing slabs are used.

Unloading of panels onsite



The panels reach their final location on a trailer and are unloaded onto the site by mechanical methods.

Site layout



The final size of the tank and arrangement of the panels are marked on the load-bearing base. The exact measurements required for Olympic pools are attained.

Fitting of panels



Firstly the corner panels are fitted using a crane.



The four corners are put into place following the markings previously made on the load-bearing base.



The remainder of the panels are fitted and then joined together using anchoring bolts.



Pouring of mortar for Positioned Panels



Once the panels are correctly positioned, the additive mortar (Grout S10) is poured into the connection grooves which are designed to join the panels together.



Fitting of the hydro-expansive cord



The '**Fuga Stop**' hydro-expansive cord is placed in the groove designed for this purpose.

Construction of the base



Perimeter formwork, base slab.

Concreting of perimeter reinforcement



Completion of perimeter formwork, floor/base slab and perimeter reinforcement, and pouring in of concrete. Special care is required when vibrating concrete in areas close to the S10 panels.

S10 step by step

Finished structure: a solid system



Upon completion, the overall swimming pool becomes a single solid structure with the S10 wall panels securely embedded within the base. This method of assembly is considerably more solid and stable compared to other precast assembly systems.

Sealing of joints



The vertical and horizontal joints are then sealed using polyurethane sealant.



Completion of the tank



The construction work on System 10 is now completed.
A totally watertight tank is delivered.
Rendering is not necessary. The surface is keyed perfectly due to the "Hidroelastic" membrane and is ideally suited for filling directly onto surface.

Water tightness testing



Once the polyurethane has polymerised, the pool must be tested for water tightness. The tank (including the overflow channel) must be completely filled and left for approximately one week.

Additional work



The following additional construction work is conducted within the tank:

- Ramps and Falls to Floor
- Pool edging
- Steps (if not embedded)
- Fitting of accessories, etc.

Waterproofing



A final waterproof membrane is applied prior to the tile being fixed into position. The whole of the tank is covered with two coats of cement waterproofing (Hidroelastic).

Fitting of tiles

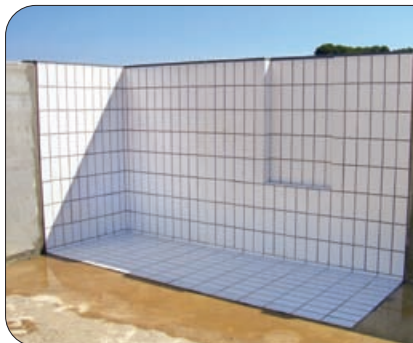

The last step is to lay the Rosa Gres ceramic tiles, which will adapt perfectly to the size of the panels and are available in a wide range of colours.



The Ergo overflow system is a convenient way of providing the pool coping and surround as well as incorporating the anti-slip finger grip for swimmers. Due to the special design of the ergo system tiles, the supports for the overflow channel grating are built into the tile reducing the overall parts to just two components. To compliment the Ergo Tile System, the pool surround, pool tank and grating components are available in matching colours that result in aesthetically pleasing solutions.

ERGO

Using Sistema Ergo®, you will be able to choose from a wide range of colours for the finish of the pool coping

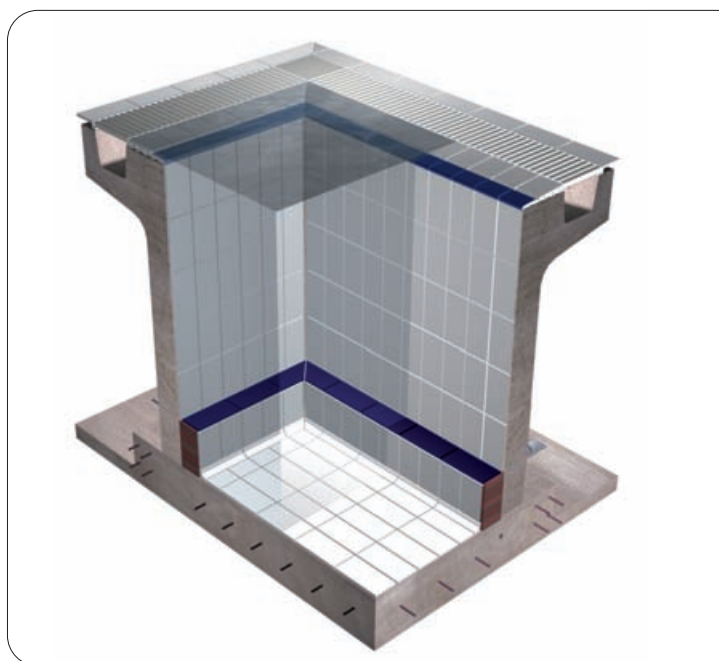
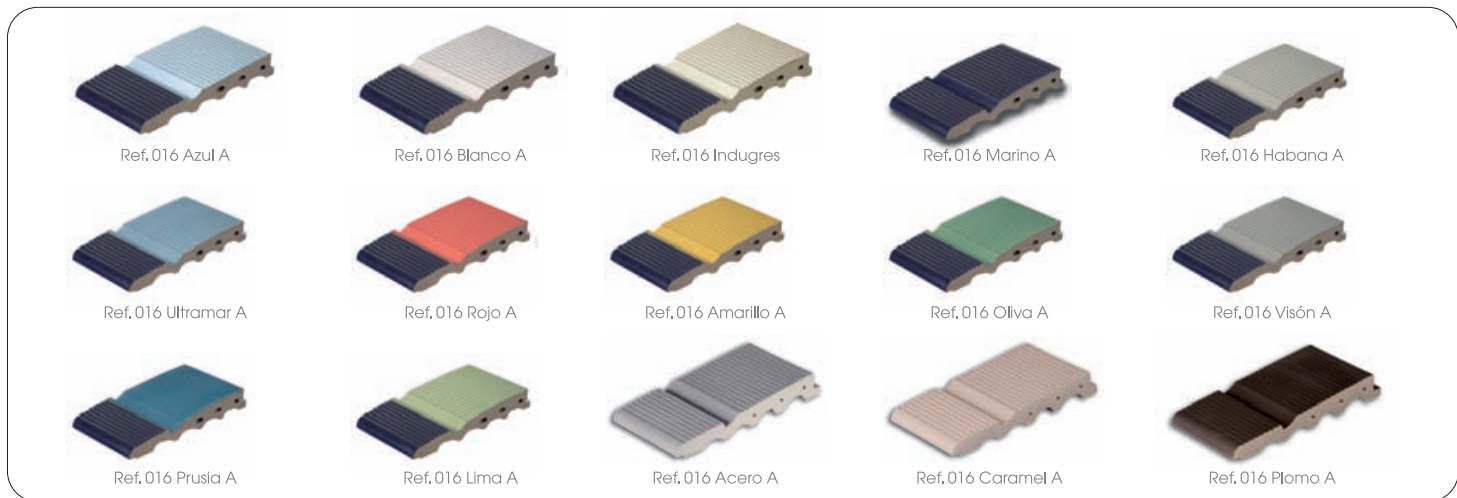

The 'Ergo' level deck system is an easy and convenient way of providing an efficient and simple pool edge including the finger grip and overflow channel grating. This is obtained by the use of only 2 components - 1) the tiles and 2) the grating (no grating supports needed). In addition, the design of the two colour 'Ergo' fingergrip pieces give a clear and highly visible denoting safety edge that can be easily identified.



S10

Advantages

Key points for using System 10

Structural calculations

A good example of sustainable construction

Short, fast construction times.

High-quality finish without the need for wall rendering.

Completely watertight pool tank, with anti-leak design between all joints in the walls and base, or walls and overflow channels caused by movement.

Exact tank size, which is essential for legally compliant competition pools.

Identical overflow channel around the edge of the pool (+/- 1mm).

Ready for tiling with porcelain stoneware tiles, the most hygienic and resistant of tiling materials.

Once completed, a solid monolithic structure is obtained, with the panels secured within the base, which is proven to be more structurally solid than other precast systems.

An elevated tank can be constructed.

An access undercroft to the external façade of the pool tank can be created.

It can be built in a wide variety of climates.

An accurate estimate is given before building work begins.

Pool tank sizes are accurate to comply with FINA and ASA Guidelines/Standards and consideration is given for the design of timing pads (if required)

In order to make the structural calculations required for **System 10**, ROSA GRES has subcontracted the services to the consultants PAMIAS, Servicios de Ingeniería S.A. It is an independent company that has been providing services to the engineering and construction sector since 1984. Moreover, these calculations have been approved by the Department of Structural Engineering at the Technical University of Catalonia by means of modelling using the finite elements method.

System 10 shows a clear engagement with sustainable architecture. Building a swimming pool using **System 10** favours:

- 1.** Rapid assembly. As a result, there is a significant reduction in the time spent on building work with the corresponding energy savings.
- 2.** Environmentally friendly due to a major reduction in waste building materials.
- 3.** Savings on the building materials used. Using precast components, the dry construction or dry assembly of the pool walls is possible. The use of formwork or mortar is not necessary for levelling the walls.
- 4.** Greater thermal inertia in comparison with other precast swimming pool systems. The concrete panels prevent rapid temperature loss of the water, thus reducing energy consumption to keep the water at an even temperature.
- 5.** The construction of raised pools, as a result of which maintenance work or possible repairs on the tank will not involve major building work.
- 6.** The prevention of leaks from the tank (if properly built), with the corresponding savings in water consumption.
- 7.** Tiling the pool using Rosa Gres ceramic products that have major environmental advantages as they are long-lasting and cost effective to maintain.

In addition, the Rosa Gres range of ceramic tiling systems for pool tanks is manufactured using energy-saving systems.

Rosa Gres has a policy of recycling waste products. Everything is re-used and put back into the production process as a raw material. Waste water is purified in a water treatment plant and reused for manufacturing.

Waste removal trucks never pass through the gates of Rosa Gres!



February 2010

THE 10 SYSTEM

PRECAST SWIMMING POOL

S-10 Sostenibilidad en Sistemas Constructivos S.L.

Ctra. Sant Cugat, km. 3
08290 Cerdanyola
Barcelona · España
Telf. +34 93 586 30 60
info@sistema10.es
www.sistema10.es

